

Model code : UKM_11MC016UK118
Print date: 17/03/2017
Last updated: 17/03/2017

Prepared for :

T 460.26 6X2 TML E6 - GVW 23.4T / GCW 44.00 T

RENAULT TRUCKS

T 460

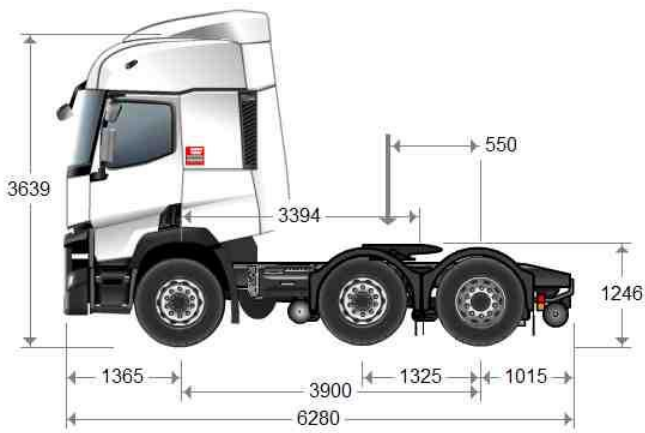

WEIGHTS

Wheelbase		mm	3.900
Maximum Weight (registered)	Total (GVW)	Kg	23400
Payload	(C)	Kg	15077
Maximum Weight (registered)	Front axle 1	Kg	7100.00
	rear axle 1	Kg	7100
	rear axle 2	Kg	11500
Min. weight complete vehicle unladen	Front axle(s)	Kg	7133.00
Kerb Weight	total	Kg	8323
	Front Axle 1	Kg	5126.00
Chassis cab kerb weight	Rear Axle 1	Kg	1220.00
	Rear Axle 2	Kg	1977.00
	Front axles (Liftable axle down)	Kg	5126
	Rear axles (Liftable axle down)	Kg	3197
	Front axles (Liftable axle up)	Kg	5466.00
	Rear axles (Liftable axle up)	Kg	2782.00
Total vehicle weight under full load at YMIN	Front axle(s)	Kg	
	Rear axle(s)	Kg	
Total vehicle weight under full load at YMAX	Front axle(s)	Kg	
	Rear axle(s)	Kg	

To maintain the driving comfort (lightness of steering, braking) of vehicles in all load and driving conditions once the vehicle is bodied, the following minimum axle load(s) must be respected: A value corresponding to 26% of the weight of the unladen bodied vehicle kerb weight (with driver, without passenger)

This table includes the weights of the RENAULT TRUCKS options: full urea tank, oil, screen wash fluid and coolant at 100%, fuel fill level 90% and driver present (75kg).



LENGTHS

Wheelbase		mm	3.900
Front Overhang	(H / BEP L016)	mm	1365
Wheelbase	(F / BEP L011)	mm	3900
Axle Spacing	Axle 2-3 (BEP L012.2)	mm	1325.00
Rear overhang	Chassis	mm	1015
Centre of Gravity of vehicle	at X (BEP L044)	mm	1316.00
Technical wheelbase	(F' / BEP L015)	mm	3394
Overall Chassis Length	(A / BEP L032+L016)	mm	6280

HEIGHTS

Wheelbase		mm	3.900
Ground clearance, laden	Front (U1 / BEP H015)	mm	233
	Rear (U3 / BEP H016)	mm	215
Max. exterior height unladen	(BEP H001)	mm	3924
Max. exterior height, cab tilted, unladen	(O1 / BEP H061)	mm	4387.00
Cab height (unladen)	(O)	mm	3639
Distance from ground to lowest point at front of vehicle	Unladen (H0 / BEP H18)	mm	355.00
	Laden (H0 / BEP H18)	mm	290.00
Frame top height at front axle	Unladen (H1 / BEP H035)	mm	995.00
	Laden (H1 / BEP H036)	mm	941.00
Frame top height at drive axle	Unladen (H2 / BEP H037)	mm	973
	Laden (H2 / BEP H038)	mm	952
Frame top height at the rear of the frame	Unladen (HN)	mm	967.00
	Laden (HN)	mm	954.00
Centre of Gravity of vehicle	Unladen at Z (BEP H044)	mm	897.00
Side member height	(BEP H032)	mm	300.00

TOWING DEVICE

Wheelbase		mm	3.900
Distance between the front of the vehicle and the centre of the trailer coupling device	(BEP L073 + L016)	mm	4715.00
Distance between centre of last axle to centre of coupling device		mm	
Fifth wheel height, from top of side member	(BEP H074 + H071)	mm	270.00
Fifth wheel height from ground	Unladen (BEP H076)	mm	1246
	Laden (BEP H078)	mm	1220
Swept Swing Clearance	(BEP L078)	mm	
Fifth wheel position	Max. (Ymax / BEP L075)	mm	1100
Gross Vehicle Weight	at YMAX	Kg	23400.00
Gross Vehicle Weight, load on front axle(s)	at YMAX	Kg	7100.00
Gross Vehicle Weight, load on rear axle(s)	at YMAX	Kg	16300.00
King Pin Load	at YMAX	Kg	15077.00
King Pin Load on Front Axle(s)	at YMAX	Kg	1974.00
King Pin Load on RearAxle(s)	at YMAX	Kg	13103.00
Fifth wheel position	Min. (Ymin / BEP L077)	mm	550
Gross Vehicle Weight	at YMIN	Kg	23400.00
Gross Vehicle Weight, load on front axle(s)	at YMIN	Kg	4800.00
Gross Vehicle Weight, load on rear axle(s)	at YMIN	Kg	18600.00
King Pin Load	at YMIN	Kg	15077.00
King Pin Load on Front Axle(s)	at YMIN	Kg	-326.00
King Pin Load on RearAxle(s)	at YMIN	Kg	15403.00
Fifth wheel position	Manufacturer's recommendation (Y / BEP L076)	mm	550
Gross Vehicle Weight	in fifth wheel position recommended by manufacturer	Kg	20505.00

Gross Vehicle Weight, load on front axle(s)	in fifth wheel position recommended by manufacturer	Kg	7100.00
Gross Vehicle Weight, load on rear axle(s)	in fifth wheel position recommended by manufacturer	Kg	13405.00
King Pin Load	in fifth wheel position recommended by manufacturer	Kg	12182.00
King Pin Load on Front Axle(s)	in fifth wheel position recommended by manufacturer	Kg	1974.00
King Pin Load on RearAxle(s)	in fifth wheel position recommended by manufacturer	Kg	10208.00
Fifth wheel position	Intermediate 1	mm	500.00
Gross Vehicle Weight	in intermediate fifth wheel position 1	Kg	21723.00
Gross Vehicle Weight, load on front axle(s)	in intermediate fifth wheel position 1	Kg	7100.00
Gross Vehicle Weight, load on rear axle(s)	in intermediate fifth wheel position 1	Kg	14623.00
King Pin Load	in intermediate fifth wheel position 1	Kg	13400.00
King Pin Load on Front Axle(s)	in intermediate fifth wheel position 1	Kg	1974.00
King Pin Load on RearAxle(s)	in intermediate fifth wheel position 1	Kg	11426.00
Fifth wheel position	Intermediate 2	mm	450.00
Gross Vehicle Weight	in intermediate fifth wheel position 2	Kg	23212.00
Gross Vehicle Weight, load on front axle(s)	in intermediate fifth wheel position 2	Kg	7100.00
Gross Vehicle Weight, load on rear axle(s)	in intermediate fifth wheel position 2	Kg	16112.00
King Pin Load	in intermediate fifth wheel position 2	Kg	14889.00
King Pin Load on Front Axle(s)	in intermediate fifth wheel position 2	Kg	1974.00
King Pin Load on RearAxle(s)	in intermediate fifth wheel position 2	Kg	12915.00
Sliding fifth wheel	front fork	mm	4.71
	rear yoke	mm	4.22

WIDTHS

Wheelbase		mm	3.900
Max exterior cab width with rear view mirrors open	(BEP W001)	mm	2534.00
Max. cab width	(BEP W002)	mm	2534
Frame width	Front (BEP W035)	mm	1080
	Rear (BEP W036)	mm	850
Width at rear wheels	Rear axle 1 (V3 / BEP W003.1)	mm	2335
	Rear axle 2 (V5 / BEP W003.3)	mm	2499.00
Track	Front (V1 / BEP W013.1)	mm	2028
	Rear 1 (V2 / BEP W013.2)	mm	2023
	Rear 2 (V4 / BEP W013.2)	mm	1837.00

OTHER

Wheelbase		mm	3.900
Approach angle	(BEP H010)	°	14
Ramp angle	(BEP H012)	°	20.90
Departure angle	(BEP H011)	°	17.00
Side member thickness	(BEP W034)	mm	7.00
Turning Radius	Overall (BEP W012)	mm	6900.00
	kerb to kerb	mm	6206.00
	interior	mm	2773.00

DTI 11 ENGINE

Max. power output: 338 kW between 1700 and 1900 rpm

Max. torque: 2200 Nm from 1000 rpm to 1400 rpm

Power output (UK): 453 hp

6-cylinder in-line diesel engine - Common rail high-pressure fuel-injection (2000 bar) - 24 valves - overhead camshaft, rear-mounted timing

High pressure provided by three pumps on injector bodies
Bore 123 mm - stroke 152 mm - Capacity 10.8 L

Turbocharger

Electronically controlled fan

Direction of rotation (seen from G/B end): anti-clockwise

EEC EURO VI pollution control level

Compact after-treatment system (catalytic converter, DPF, SCR)

Automatic regeneration of particulate filter

Soundproofing level complies with EEC standards (80dB)

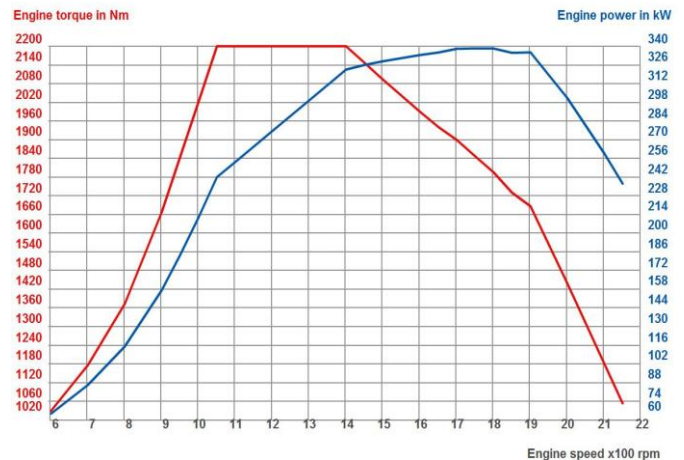

ENGINE EQUIPMENT

Power mode inhibited after passing the 'hard spot' of the accelerator pedal

Partial gas recycling (semi-closed circuit)

Automatic engine cut-off (5 min)

Without engine Power Take Off.

Electronic speed limiter (90 km/h).

CLUTCH

Single-plate clutch, diameter 430 mm

GEARBOX

Optidriver gearbox AT 2412F (14.94 - 1) automated clutch.

Aluminium housing. Max. torque 2400 Nm, 12 forward gears and 3 reverse gears

Choice of mode of use on steering wheel (automatic/manual)

Steering wheel mounted gear selector.

Gearshifting strategy optimised for FUEL ECO

Gearbox rear intermediate housing in aluminium

RETARDER

OPTIBRAKE (power rating 300 kW at 2300 rpm), combination of the exhaust brake and valve compression braking, coupled to service brake

POWER TAKE-OFFS

Without gearbox mounted PTO

STEERING

Right hand drive.

Hydraulic power steering, variable flow pump

Steering ratio 20:1 - Steering wheel diameter 460 mm

Driving on the left

FRONT AXLE

Load capacity (technical max.) Front axle: 7.1 t.

REAR AXLE

Liftable rear axle

Load transfer to drive axle (10.5 t + 30% if speed below 30 km/h)

Rear axle position : in front of engine drive axle

REAR DRIVE AXLE

P13170-D single reduction final drive axle

Differential lock

Rear loading capacity (technical max.): 19 t

Rear load 7.1t - 11.5t

Drive axle ratio: 2.64

Engine speed at 90 km/h: 1280 rpm

WHEELS AND TYRES

Dimension 315/70 R 22.5

C. HYBRID HS3 XL / HD3 profile

Steel disc wheels

Front wheel trims

Without spare wheel.

BRAKING

Service brake:

Braking system with two independent circuits

Ventilated disc brakes

Electronic management of air production by EACU (Electronic Air Control Unit):

Dryer cartridge optimised by preventive maintenance.



Twin-cylinder air compressor 900 l/min, 636 cm³

Disengageable compressor

Brake hose couplers, UK standard

Additional electric lead 15 pin, 2x7 pin.

Trailer brake device at cab rear

EBS:

Anti-lock braking system (ABS).

Anti-slip regulation (ASR).

Drag torque control (Torque control during downshifting).

Brake harmonisation of tractor and trailer (if equipped)

(Disc) brake pad wear compensation

Retarder and service brake linking

Differential engagement management (if equipped) at speeds <10 km/h (4x2)

Hill Start Aid

Braking performance warning

ESC (Electronic Stability Control) trajectory control and anti-rollover system

Coupling traction test

Emergency brake assist (EBA)

Emergency brake lights (EBL)

Parking brake:

EPB (Electronic Parking Brake) automatic parking brake, immobilization provided by spring cylinders

Brake adjustment:

Automatic brake lining slack compensation.

Emergency brake:

Ensured by independence of main device circuits

CAB

Cab exterior:

All steel Cab, electro-zinc plated and cataphoretic paint treatment.

Sleeper Cab

Cab paint colour: WHITE EKLA

Dark grey front face finish

Black fog lamp trims

Aerodynamic dirt deflectors on the headlamps

4-point cab air suspension with ride-height control system

Two side doors of which one is accessible from inside the cab

2 heated, remote control rear view mirrors.

2 wide angle rearview mirrors.

Kerb view mirror.

Rear view mirrors for bodywork up to 2.55 m wide

Fold-back front view mirror

Rearview mirrors silver finish

Air horn

Spray suppression on front wings

Side deflectors (2 opening panels)

Adjustable roof deflector.

Door extension

Cab accessories: cab colour

External sun visor.

Without rear window.

Cab interior:

Ultimate Alu finish

Ultimate roof console, luxury head lining, 4 storage compartments with doors including 1 with key lock, 1 storage space with net, 4 ISO modules

Electric interior sun blind on windscreen, manual blinds on driver and passenger side windows

Mono CD player, MP3/WMA format-compatible

Double tuner for immediate radio station list update

Steering column-mounted radio controls

Jack (3.5 mm) and USB inputs for MP3 player

Hands-free interface for mobile telephone (Bluetooth technology), Audio streaming, steering wheel controls,

microphone in the roof console, audio playback through vehicle speakers

Information on the main information display

CB pre-equipment.

Dual CAN digital tachograph

Offset 24 V socket

Electrically operated roof hatch.

Mosquito net on air vent

Interior roof grab handle

Rubber floor mat

Air-suspended driver's seat with fitted seat belt, adjustable lumbar support, adjustable seat cushion extension, heated seat (0-1-2)

Two driver's armrests

Safety belt warning.

Air-suspended passenger seat with seatbelt.

Passenger armrest

Cloth seat trim.

Performance lower bunk

Ultimate upper bunk, transformable into storage with access ladder and luggage net

Air supply to the rear of the driver's seat

Drawer under bunk with document holder

Reading lamps on overhead ledge

Direct cab lighting

Red night lighting

Cab lighting time-delay.

Curtains around cab.

Articulated LED lamps in bunk area

Bunk area remote control

12 and 24 V sockets on bunk

Provision for 50A max. electrical power supply

24L refrigerator in central storage under bench, quiet with thermostat and vehicle battery management

2 storage boxes under bunk, one accessible from interior and exterior

2 Coat hooks on rear panel and one on passenger side

One-touch electric windows

Cab independent night heater air/air (2 kW)

Electronically regulated comfort air conditioning with compressor optimisation

Cab air filtration

Handbook and Service pack in English.

2 loudspeakers.

Steering wheel equipment:



Ultimate leather steering wheel with cruise control and telephone control
OPTIDRIVER control
OPTIBRAKE and retarder control on right-hand side
Easy Access steering column adjustable in 3 directions
Removable writing board on steering wheel

Instrument panel:

7" HD colour information display
Speedometer in miles
12 V + 24 V socket on dashboard, for accessories.
Starting inhibitor controlled by transponder key.
Remote control central door locking with folding key
Two additional ignition keys
ECO Cruise control with Optiroll

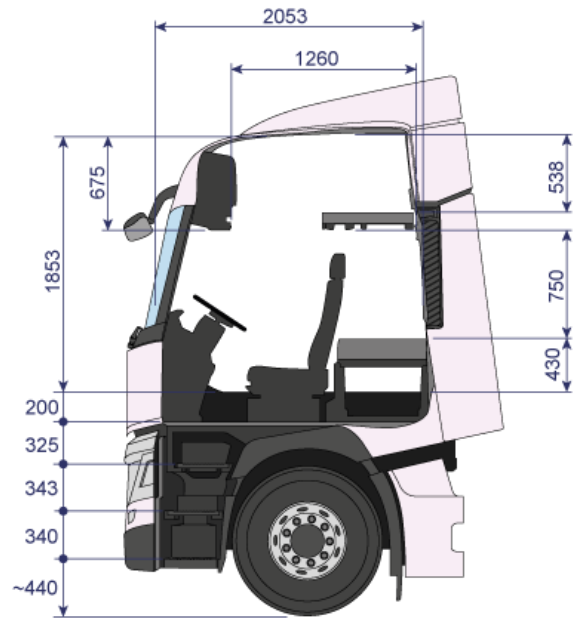
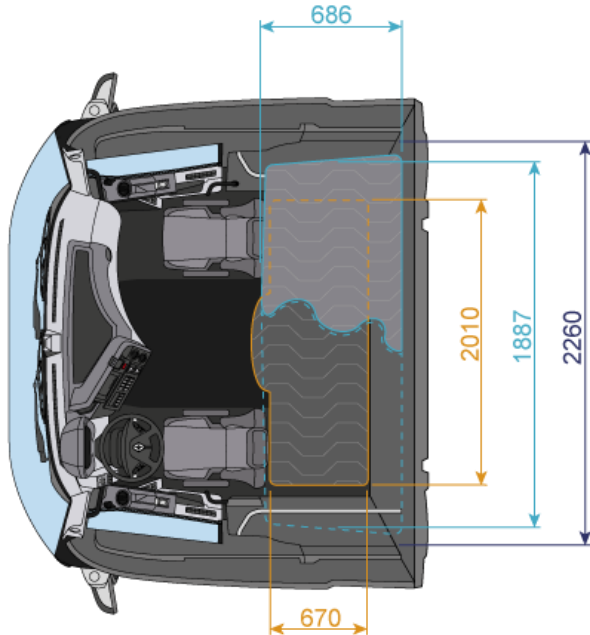

ELECTRONIC EQUIPMENT:

SAE cab socket for vehicle data extraction (Optifuel Infomax).
FMS Gateway fleet management interface
Telematics provision including the TGW (Telematics GateWay): base for subscription to Optifleet Map, Check and Drive services
Lane Departure Warning System (LDWS)
Automatic emergency braking system
English and French language display
Additional language (Spanish)

ELECTRICAL EQUIPMENT

Battery capacity: 225 Ah
Batteries located in the rear overhang
Battery cut-out remote control
Electrical circuit automatically goes to standby
Battery charge indicator
Alternator : 150 amp capacity.

CHASSIS

Removable front towing cap.
Front under-run protection.
Transmission crossmember Reinforced
Closing cross member with pre-drilling for towing yoke
Manual sliding medium fifth wheel mounting H=50 mm
Sheet metal Fontaine SP150 (sheet metal) 2" fifth wheel, D 150 kN
Fifth wheel position: Y = 550 mm
Extended rear platform.
Rear wings with anti-spray
Wings fitted in standard position.
Side exhaust.



BUMPER - STEPS AND LIGHTING

3-part plastic bumper
Retractable windscreen access step in radiator grille
Access to driving position by 3 steps
Step lighting.
Electrical headlamp levelling control.
LED day running lights
Provision for lighting rail on front end
Coupling light (70W).
Front fog lights.
Halogen headlights
Roof beacon pre-equipment

SUSPENSION

Front suspension

2-leaf front leaf springs
Stabiliser bar

Rear suspension:

Air suspension
Suspension remote control (2 channels).

FUEL TANK

Main aluminium tank
Main fuel tank: 480 litres capacity D710 profile mounted on left & with access steps
Anti-siphoning device

GEARBOX RATIOS

1	2	3	4	5	6	7	8	9	10	11	12
14.94	11.73	9.04	7.09	5.54	4.35	3.44	2.70	2.08	1.63	1.27	1.00

The manufacturer reserves the right to modify the specifications above without prior notice.

Non contractual document.

For further assistance please contact Product Applications at Renault Trucks UK Limited, Wedgnock Lane , Warwick , CV34 5YA Telephone +44 (0)1926 475333.

Sedimenter and prefilter (R60). Bleed control on dashboard.

AdBlue

64-litre AdBlue tank (D710)
Tank on the right

STANDARD EQUIPMENT

Tool kit.
Reversing warning buzzer, including night switch.
Windscreen washer bottle capacity: 12L

BODYWORK

Side marker lights.
Interface for bodybuilder connections and BBM module (Body Builder Module)

SERVICE

Optifleet:

Pre-equipment for monthly Optifleet Check: technical data reports for fuel consumption monitoring by vehicle and by driver, activation of service on request subject to monthly subscription
Pre-equipment for monthly Optifleet Map: vehicle geolocation, geofencing and route analysis. Activation of service on request subject to monthly subscription

